

first there is an $\sim 20\%$ increase in the $\alpha\beta\text{P}^*$ fluorescence signal, followed by a slow, first-order decay. This increase in fluorescence signal intensity may be due to the transient increase in concentration of the $\{\alpha\beta\text{P}^*\}_o$ intermediate, assuming that this intermediate has a conformation such that the fluorescence quantum yield is larger than it is for $\{\alpha\beta\text{P}^*\}_c$.^{16,17} Previous work² has provided evidence for a kinetic intermediate in the dissociation of FpCyt $c(88-104)$ from I-E^k.

The activation energy ΔH^* for reaction 1 was estimated by studying the dissociation rates over the 20–40 °C temperature range and fitting the long time decay portion of the 20–30 °C biphasic curves to a single exponential. Our estimate is that $\Delta H^* = 10 \pm 3$ kcal/mol, with a frequency factor of 20 ± 4 s⁻¹.

To summarize, the thrust of the present letter is to argue that the equality of the kinetic off rates implies (at least) a two-step kinetic reaction mechanism (1–2), such that the rate-limiting step is peptide structure-independent. Of course, this argument does not imply that this result will be found with I-A^d and all other peptides, nor with other class II MHC–peptide combinations. Even so, it is probable that mechanism 1–2 will apply to most peptide dissociation reactions from class II MHC proteins.

Acknowledgment. We thank Mohandas Pai of Anergis, Inc., for the synthesis of the ovalbumin peptides. This work was supported by a Stanford University Training Program in Immunology fellowship (AI-07290, S.N.W.) and by a National Institutes of Health grant (5R01 AI13587-13).

(16) This increase of fluorescence intensity might also arise if a population of molecules with the closed conformation contained two fluorescent peptides with fluorescence quenching. The loss of one fluorescent peptide in the open conformation would then lead to enhanced fluorescence per heterodimer. Energy transfer between a fluorescent peptide donor and a fluorescent peptide acceptor bound to a single MHC molecule has been reported.¹⁷

(17) Tampe, R.; Clark, B. R.; McConnell, H. M. *Science* 1991, 254, 87–89.

The Osmium Tetrahydroxydisiloxane, $[\text{OsCl}(\text{CO})(\text{PPh}_3)_2\text{Si}(\text{OH})_2]_2\text{O}$, from the Coordinatively Unsaturated Trihydroxysilyl Complex, $\text{Os}(\text{Si}[\text{OH}]_3)\text{Cl}(\text{CO})(\text{PPh}_3)_2$

Clifton E. F. Rickard, Warren R. Roper,* David M. Salter, and L. James Wright*

Department of Chemistry, University of Auckland
Private Bag 92019, Auckland, New Zealand

Received June 19, 1992

Revised Manuscript Received September 8, 1992

The hydrolysis of organotrichlorosilanes (RSiCl_3) typically leads to cross-linked polymeric siloxanes.¹ If the organo groups are large and carefully controlled conditions are employed, oligosilsesquioxanes² or even organosilanetriols³ can sometimes be isolated. In contrast, the hydrolysis and condensation reactions of transition metal trichlorosilyl complexes (L_nMSiCl_3) have been much less studied.⁴ In this communication we report the synthesis and structure of the first transition metal trihydroxysilyl complex⁵

(1) Aylett, B. J. *Organometallic Compounds, Vol. 1, Part Two: Groups IV and V*, 4th ed.; Chapman and Hall: London, 1979; pp 1–130.

(2) See, for example: Feher, F. J.; Budzichowski, T. A.; Blanski, R. L.; Weller, K. J.; Ziller, J. W. *Organometallics* 1991, 10, 2526–2528. Agaskar, P. A. *Inorg. Chem.* 1991, 30, 2707–2708 and references therein.

(3) (a) Ishida, H.; Koenig, J. L.; Gardner, K. C. *J. Chem. Phys.* 1982, 77, 5748–5751. (b) Al-Juaid, S. S.; Buttrus, N. H.; Damja, R. I.; Derouiche, Y.; Eaborn, C.; Hitchcock, P. B.; Lickiss, P. D. *J. Organomet. Chem.* 1989, 371, 287–295.

(4) (a) Aylett, B. J. *Adv. Inorg. Chem. Radiochem.* 1982, 25, 1–133. (b) Mackay, K. M.; Nicholson, B. K. In *Comprehensive Organometallic Chemistry*; Wilkinson, G., Stone, F. G. A., Abel, E. W., Eds.; Pergamon Press: Oxford, 1982; Vol. 6, pp 1043–1114. (c) Gloecking, F.; Houston, R. E. *J. Organomet. Chem.* 1973, 50, C31–C32.

(5) A monohydroxysilyl complex of platinum (formed by hydrolysis of an ortho-metalated phenylsilyl ligand) was recently reported: Chang, L. S.; Johnson, M. P.; Fink, M. J. *Organometallics* 1991, 10, 1219–1221.

Scheme 1^a

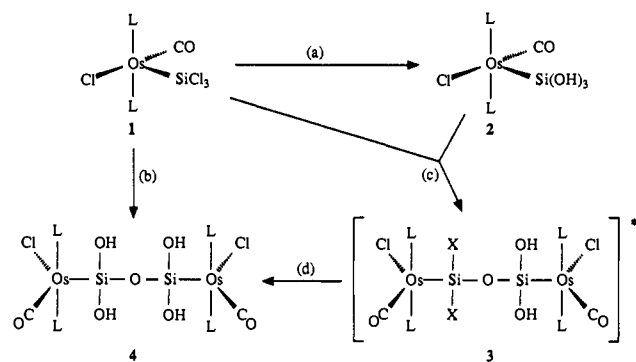

^a (a) 3 equiv of OH^- in THF/ H_2O (high yield, 85%); (b) ca. 1 equiv of OH^- in THF/ H_2O (low yield, <10%); (c) reaction of 1 with 1 equiv of compound 2 (high yield); (d) H_2O (high yield, 70% overall); L = PPh_3 , X = Cl or OH, *postulated intermediate.

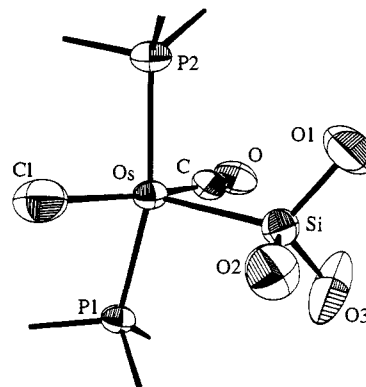

Figure 1. ORTEP view of 2 with the phenyl rings of the PPh_3 ligands omitted for clarity. Thermal ellipsoids at the 50% probability level. Important distances (Å) and angles (deg): Os–Si, 2.319 (2); Si–O(1), 1.647 (5); Si–O(2), 1.649 (5); Si–O(3), 1.624 (5); Si–Os–Cl, 104.6 (1); Si–Os–C, 86.4 (2).

($\text{Os}(\text{Si}[\text{OH}]_3)\text{Cl}(\text{CO})(\text{PPh}_3)_2$, 2) and the first dimetallo tetrahydroxydisiloxane⁶ ($[\text{OsCl}(\text{CO})(\text{PPh}_3)_2\text{Si}(\text{OH})_2]_2\text{O}$, 4), both of which can be obtained via hydrolysis of $\text{Os}(\text{SiCl}_3)\text{Cl}(\text{CO})(\text{PPh}_3)_2$ (1).⁷

Treatment of 1 with aqueous sodium hydroxide in tetrahydrofuran rapidly produces the yellow, coordinatively unsaturated trihydroxysilyl complex $\text{Os}(\text{Si}[\text{OH}]_3)\text{Cl}(\text{CO})(\text{PPh}_3)_2$ (2) (ca. 85%) (Scheme 1). New bands in the infrared spectrum of 2 at 3616, 828, and 777 cm^{-1} are assigned to the trihydroxysilyl group. A broad signal in the ^1H NMR spectrum at 2.38 ppm, which integrates for three protons and disappears on addition of D_2O , is assigned to the resonance of the $\text{Si}(\text{OH})_3$ protons. Unambiguous characterization has been achieved by a single-crystal X-ray structure determination,⁸ and an ORTEP diagram of 2 is shown in Figure 1.

The geometry about osmium is essentially square pyramidal with the silyl group in the apical position. The Os–Si bond length of 2.319 (2) Å is one of the shortest that has been reported,⁹ and

(6) The dimetallo disiloxanes $\text{trans}[\text{PtX}(\text{PEt}_3)_2(\text{SiH}_2)]_2\text{O}$ (X = Cl, Br, I) have been reported to form on reaction of $\text{trans}[\text{PtHX}(\text{PEt}_3)_2]$ with the disiloxane $(\text{SiH}_3)_2\text{O}$: Ebsworth, E. A. V.; Edward, J. M.; Rankin, D. W. H. *J. Chem. Soc., Dalton Trans.* 1976, 1667–1672. A cyclometallo disiloxane reportedly forms on hydrolysis of $\text{Pt}(\text{SiCl}_3)_2(\text{PPh}_3)_2$ (see ref 4c).

(7) Clark, G. R.; Rickard, C. E. F.; Roper, W. R.; Salter, D. M.; Wright, L. J. *Pure Appl. Chem.* 1990, 62, 1039–1042.

(8) Yellow crystals of 2 were grown by slow diffusion of *n*-hexane into a dichloromethane solution of 2 at 4 °C. Crystal data: $a = 13.664$ (3), $b = 12.355$ (2), $c = 20.278$ (4) Å, $\beta = 95.50$ (2)°, $Z = 4$, $d(\text{calcd}) = 1.670$ g cm^{-3} , space group $\text{P}2_1/c$. A total of 5290 reflections ($I > 3\sigma(I)$) were collected on a Nonius CAD-4 diffractometer at 293 K using $\text{Mo K}\alpha$ radiation ($\lambda = 0.71069$ Å). Least-squares refinement converged to $R(F) = 0.037$ and $R_w(F) = 0.042$.

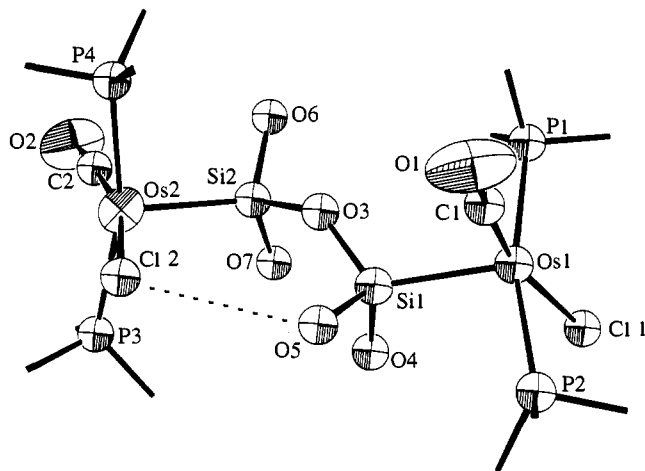

Figure 2. ORTEP view of **4** with the phenyl rings of the PPh_3 ligands omitted for clarity. Thermal ellipsoids at the 50% probability level. Important distances (Å) and angles (deg): Os(1)–Si(1), 2.318 (5); Si(1)–O(3), 1.637 (10); Os(2)–Si(2), 2.337 (5); Si(2)–O(3), 1.645 (10); Si(1)–O(3)–Si(2), 137.9 (7).

this may be attributed to both the electronegative substituents on silicon and the fact that the complex is only five coordinate.^{4a,b,10} Within the trihydroxysilyl group, all three Si–O distances and Os–Si–O angles are very close to normally observed values.^{5,10,11} Importantly, there is no indication of any interaction between the oxygen atoms and the coordinatively unsaturated osmium center.

A remarkable feature of the structure of **2** is that the trihydroxysilyl group is not involved in any significant hydrogen-bonding interactions to oxygen or chlorine. The intramolecular O(2)–Cl distance of 3.65 Å falls well outside the range of 2.92–3.18 Å observed for typical O–H···Cl hydrogen bonds.¹² The closest intermolecular approaches involving the Si(OH)₃ oxygen atoms are those made to the carbon atoms of an adjacent triphenylphosphine ligand (3.32 Å).¹³ Only three organosilanetriols have been structurally characterized,³ and in each case extensive intermolecular hydrogen-bonded networks in the form of sheets or polyhedral cages are evident. The absence of intermolecular hydrogen bonding in **2** is most probably due to the steric shielding afforded by the two mutually trans triphenylphosphine ligands.

If the hydrolysis of **1** is carried out in the presence of less than stoichiometric amounts of aqueous sodium hydroxide, small amounts of the diosmium tetrahydroxydisiloxane [OsCl(CO)-(PPh₃)₂Si(OH)₂]₂O (**4**) are formed along with **2**. Much larger yields of this compound (ca. 70%) are obtained if equimolar quantities of **1** and **2** are allowed to react together in water-saturated dichloromethane. Partial or complete hydrolysis of **1** may precede the dimerization step which could be acid catalyzed (Scheme 1).

The single-crystal X-ray structure of **4** has been determined,¹⁴ and an ORTEP diagram is shown in Figure 2. Although there

are no intermolecular hydrogen bonds evident in the structure, the Cl(2)–O(5) distance of 3.17 Å suggests that this one SiOH group is involved in a weak intramolecular hydrogen bond to chloride (see Figure 2).^{12,15} This interaction may be responsible for the relatively small Si–O–Si angle in **4** as well as the difference (which is probably significant) in the two Os–Si distances.

The two new compounds **2** and **4** can be viewed as derivatives of orthosilicic acid (H₄SiO₄) and pyrosilicic acid (H₆Si₂O₇), respectively, in which one of the hydroxy groups on each silicon atom has been substituted by a transition metal, viz. L_nMSi(OH)₃ and L_nMSi(OH)₂OSi(OH)₂ML_n. As such they represent the first examples of these new classes of compounds. The unused functionality at silicon in these compounds and the coordinative unsaturation at osmium offer many opportunities for further synthetic transformations, and these possibilities are being explored.

Acknowledgment. We thank the University of Auckland Research Committee for partial support of this work through a grant in aid to W.R.R. and L.J.W.

Supplementary Material Available: Tables of atomic coordinates, thermal parameters, bond angles, and bond distances for **2** and **4**, preparative details, combustion analyses, and IR and ¹H, ³¹P, and ²⁹Si NMR spectral data for **2** and **4** (14 pages); tables of observed and calculated structure factors (30 pages). Ordering information is given on any current masthead page.

(15) Other intramolecular approaches involving the Si(OH)₂ oxygen atoms and the phenyl rings of **4** are O(6)–C(63), 3.04 Å, and O(4)–C(40), 3.20 Å.

Control of Dispersity in Stereoselective Telomerizations: The Addition/Cyclization/Transfer Strategy

Gregory S. Miracle, Scott M. Cannizzaro, and Ned A. Porter*

Department of Chemistry, Duke University
Durham, North Carolina 27706

Received August 27, 1992

There are a variety of natural products and organic substructures that possess a carbon skeleton with a precise number of repeating chiral units. Traditional approaches to the construction of these substructures require successive additions of repeating units and can be prohibitively long and inefficient. Free radical telomerization has the potential of connecting multiple repeating units in a single step, but this second approach suffers from two fundamental limitations: (1) difficulty in controlling telomer distribution and (2) lack of stereochemical control. Existing strategies to the telomer distribution problem include the spanning strategy pioneered by Feldman,¹ who has proposed the term *oligoselectivity* to describe size control in oligomerization reactions. A second approach^{2,3} employs covalent attachment of monomer units to a template and relies on the potential advantage of intramolecular addition reactions compared to intermolecular reactions.

We have developed a rational strategy that integrates our expertise in both acyclic stereocontrol⁴ and radical macro-

(9) Woo, L. K.; Smith, D. A.; Young, V. G., Jr. *Organometallics* **1991**, *10*, 3977–3982. Adams, R. D.; Cortopassi, J. E.; Pompeo, M. P. *Inorg. Chem.* **1991**, *30*, 2960–2961.

(10) Tilley, T. D. In *The Chemistry of Organic Silicon Compounds*; Patai, S., Rappoport, Z., Eds.; Wiley: New York, 1989; Chapter 24, pp 1415–1477.

(11) Sheldrick, W. S. In *The Chemistry of Organic Silicon Compounds*; Patai, S., Rappoport, Z., Eds.; Wiley: New York, 1989; Chapter 3, pp 227–303.

(12) Greenwood, N. N.; Earnshaw, A. *Chemistry of the Elements*; Pergamon Press: Oxford, 1984; Chapter 3, pp 38–74 and references therein.

(13) The closest intramolecular approach involving the Si(OH)₂ oxygen atoms and the phenyl rings of **2** is 3.17 Å (O(2)–C(26)). π–HO bonding has been considered in other silanol structures: Al-Juaid, S. S.; Al-Nasr, A. K. A.; Eaborn, C.; Hitchcock, P. B. *J. Chem. Soc., Chem. Commun.* **1991**, 1482.

(14) Yellow crystals of **4** were grown by slow diffusion of ethanol into a dichloromethane solution of **4** at 4 °C. Crystal data: *a* = 10.494 (6), *b* = 18.316 (3), *c* = 19.527 (3) Å, α = 92.84 (1), β = 92.86 (2), γ = 101.05 (3)°, *Z* = 2, *d*(calcd) = 1.534 g cm⁻³, space group P1. A total of 4627 reflections (*I* > 3σ(*I*)) were collected on a Nonius CAD-4 diffractometer at 293 K using Mo Kα radiation (λ = 0.71069 Å). Least-squares refinement converged to *R*(*F*) = 0.049 and *R*_w(*F*) = 0.051.

(1) (a) Feldman, K. S.; Bobo, J. S.; Ensel, S. M.; Lee, Y. B.; Weinreb, P. H. *J. Org. Chem.* **1990**, *55*, 474. (b) Feldman, K. S.; Lee, Y. B. *J. Am. Chem. Soc.* **1987**, *109*, 5850.

(2) (a) Kammerer, H.; Hegemann, G. *Makromol. Chem.* **1984**, *185*, 635. (b) Kammerer, H.; Hegemann, G.; Onder, N. *Makromol. Chem.* **1982**, *183*, 1435. (c) Kammerer, H.; Steiner, V.; Gueniffey, H.; Pinazzi, C. P. *Makromol. Chem.* **1976**, *177*, 1665. (d) Kammerer, H.; Shukla, J. S. *Makromol. Chem.* **1968**, *116*, 62. (e) Wulff, G. In *Recent Advances in Mechanistic and Synthetic Aspects of Polymerization*; Fontanille, M., Guyot, A., Eds.; D. Reidel: Boston, 1987; p 399.

(3) Shea, K. J.; O'Dell, R.; Sasaki, D. Y. *Tetrahedron Lett.* **1992**, *33*, 4699.

(4) Porter, N. A.; Giese, B.; Curran, D. P. *Acc. Chem. Res.* **1991**, *24*, 296.